

苏州新值机械有限公司
SUZHOU NEW VALUE MACHINERY CO.,LTD



综合样本

COMPANY BROCHURE

技术和销售办公室: 苏州市工业园区展业路18号中新生态科技城B幢

Technical & Sales Office: Building B, Zhongxin ecological science and Technology City, No.18, zhanye Road, Suzhou Industrial Park.

测试中心和工厂厂房: 常州市金坛区盐港东路39号12幢6号

Factory & Testing Centre: No. 6, Building 12, No. 39, Yangang East Road, Changzhou.

 www.newvaluemachinery.com

 info@newvaluemachinery.com

 0512 - 6572 9632

 隋先生 Mr. Sui 罗女士 Ms. Luo

 18151587190 18151587182



网站二维码
Website QR code

苏州新值机械有限公司
SUZHOU NEW VALUE MACHINERY CO., LTD

目录 CONTENTS

01	公司介绍 About Us	-----	1-5
-----------	-------------------------	-------	-----

02	设备单元 Equipment Unit	-----	6-22
-----------	-------------------------------	-------	------

逐层式自动拆包机	Automatic Bag Opening Machine	6
逐袋式自动拆包机	Automatic Bag Opening Machine	7
25KG手动拆包机	25KG Manual Unpacking Station	8
吨包拆包卸料站	Big-bag Discharge Station	9
发送罐	Feed-tank	10
空气控制单元	Air Control Unit	11
粉料负压吸料机	Powder Negative Pressure Receiver	12
模块化负压吸料机	Modular Vacuum Receiver	13
真空泵	Vacuum Pump	14
手动配料站	Manual Coupling Station	15
自动配料站	Automatic Coupling Station	16
高压旋转阀	High pressure rotary valve	17
失重式计量系统	Loss-in-weight Dosing System	18

目录 CONTENTS

称重式计量系统	Gravimetric Dosing System	19
体积式混料机	Volumetric Doser	20
掺混料仓	Blending Silo	21
普通储料仓	Storage Silo	22

03	气力输送系统 Pneumatic conveying system	-----	23-29
-----------	---	-------	-------

正压密相发送罐气力输送系统	Positive Pressure Dense Phase Pneumatic Conveying System	23
正压密相高压锁气阀气力输送系统	Positive Pressure Dense Phase High Pressure Lock Valve Pneumatic Conveying System	25
正压稀相气力输送系统	Positive Pressure Dilute Phase Pneumatic Conveying System	26
负压稀相气力输送系统	Negative Pressure Dilute Phase Pneumatic Conveying System	27
负压密相气力输送系统	Negative Pressure Dense Phase Pneumatic Conveying System	28

04	行业应用 Industry Applications	-----	30-36
-----------	--------------------------------------	-------	-------

公司介绍 About Us



企业文化 Corporate Culture

- 以客户需求为导向
 - 以技术创新为核心
 - 以产品质量为灵魂
 - 以客户服务为重点
 - 以项目管理为基础
- Customer needs oriented
 - Take technological innovation as the core
 - Take product quality as the soul
 - Focus on customer service
 - Based on project management



我们的团队优势 Our Team

- 丰富的行业应用经验
 - 全面的解决方案
 - 基于成熟技术的再创新
 - 客户定制化设计
 - 丰富的项目管理经验
- Rich industry application experience
 - Comprehensive solution
 - Innovation based on mature technology
 - Customized devise
 - Rich project management experience

苏州新值机械有限公司 SUZHOU NEW VALUE MACHINERY CO.,LTD

苏州新值机械有限公司是一家以国务院颁布的《中国制造2025》为指导，以做强中国民族制造业为己任，以专业、创新、为客户创造重要价值为宗旨的技术型公司。

我们致力于在气力输送相关技术和应用上，做最专业、精通的公司。结合行业内丰富的应用经验，研究国内外最先进的行业技术，拥有最先进和最全面的解决方案。遵循使设备模块化、操作维护简便等实用的设计理念，保证系统设备运行稳定可靠、智能、节能、高效。我们注重于提供与客户需求最匹配的系统设备，在客户低成本投入的基础上，为客户额外创造最高的附加价值。

Suzhou New Value Machinery Co., Ltd. (NVM) is a technology-based company, guided by the "Made in China 2025" promulgated by the State Council, with the mission of strengthening China's national manufacturing industry, and with the purpose of being professional, innovative, and creating important value for customers.

We are committed to being the most professional and proficient company in pneumatic conveying related technology and application. Combined with rich application experience in the industry, study the most advanced industry technology at home and abroad, and have the most advanced and comprehensive solutions. Follow the practical design concepts of modularization of equipment and simplification of operation and maintenance to ensure the stable, reliable, intelligent, energy-saving and efficient operation of the system. We focus on providing the system that best matches the needs of customers, and create the highest added value for customers on the basis of low-cost investment.

科技研发 Technolog Research and Development

新值企业以“不断创新，制造精品”为技术原则，始终把技术开发放在企业一切活动之首。研发部门以不断满足市场需求为出发点，创造性地开发新产品。同时还经常性地研究市场现有的产品，为不断改进产品性能，使之达到更好的使用效果。新值机械不仅在研发新品上出类拔萃，更能够把客户不同的需要和要求作为设计输入，量身定做符合他们具有特殊需求的产品，更好地满足客户的实际需求。

NVM follows the technical principle of "keep innovative for finest products" and always put technical development in the first place with consideration of meeting market demands to creatively develop new products and regular researches are made on the existing products on market to improve product performance and maximize the life cycle. We are not only outstanding in new product development, but capable to offer customized products as per customers' special requirements to satisfy customers' actual need to fullest extent.

不断创新，以提供更优质、更可靠的产品和技术为企业核心竞争力。科技之于客户，是价值，是为客户创造持续增长的价值。新值每一次成长，迸发出每一滴每一点的实效光辉，以“为客户创造价值”为核心，不断创新产品和提升服务质量，最终实现客户的价值更大化。

Continuous innovation, to provide higher quality and more reliable products and technologies as the core competitiveness of the enterprise. Science and technology is to the customer, is value, is a sustained growth for the customer creation value. Every time our NVM grows, it will burst out every drop and every bit of practical brilliance. With "creating value for customers" as the core, it will continue to innovate products and improve service quality, and finally realize the greater value of customers.

生产设备 Production Equipment

工欲善其事，必先利其器。精良的设备代表着企业拥有强大的生产能力，并确保高质量的产品品质。先进的高、精、尖设备保证看高品质的产品。先进的自动化生产设备，精良的流水线制作，尽显优秀品质。技术专家直接参与生产，保证产品的稳定性和可靠性。与日俱增的精品意识和源源不断的工业精品令我们的设备精益求精。不管世界如何变化，锐意进取、创造精品是我们不变的精神。

Sharp tools make good work. Sophisticated equipment means that the enterprise has strong production capacity and ensures high-quality product quality.

The advanced high-tech, refined and sophisticated equipment guarantees high-quality products. Advanced automatic production equipment and fine flow line manufacturing display the first class quality. The direct participation to production by technical experts guarantees the stability and reliability of products. Thanks to the increasingly enhanced conception of fine products and continuous in dustrial fine products, our equipment have been kept improving. No matter how the world is changing, the clinging spirit of us to keep enterprising and create fine will never change.



工厂一角

检测设备 Testing Equipment

品质是企业生存和发展的原动力，是新值公司企业文化精神的基石。新值一贯努力建设创新环境，营造竞争机制，增强员工创新意识，不断提高员工创新能力。企业重视信息导向，将新知识高科技应用于产品改造和技术革新，研发能力日益增强，新产品、新工艺层出不穷，企业活力充沛，生机无限。

Quality is the primitive power for survival and development of the enterprise and the base of enterprise cultural spirit of NVM Company.

NVM is always striving for constructing innovative environment, creating innovative atmosphere, introducing competition system, enhancing innovative conception of employees and continuously improving innovative ability of employees. The enterprise pays much attention to the information guide, and applies new knowledge and advanced technology into product reformation and technical innovation. The research and development ability of our company has been increasingly enhanced with more and more new products and new technologies emerging. The enterprise is full of vigor and boundless vitality.



测试中心 Test Center



测试中心 Test Center

新值有设备全面的最专业的技术测试实验室。实验室现有的散料物料数据库，依据超过2000份散料物料样品，仔细确认得出的性能数。如：空气消耗量，输送压力，速度和最大产能，料气比等。

实验室可以对客户特定散料进行全面测试，以得出特定散料的实际的输送性能，确定最佳的系统运行参数。主要包括：

- 得到核实的重要的系统设计信息。如物料的可输送性，流动性性能等。
- 得到系统设备调试运行的优化时间，程序逻辑等。
- 得到输送运行后的物料实际品质质量。如物料的降级性，混合物料的偏析性等。
- 得出系统的实际运行性能。如：耗气量，集尘量等。
- 客户关心的其他性质。如：物料的粒径分布，流动性等。

与此同时，创新不仅仅停留在产品层次，因为我们深深懂得产品只是客户需求的一部分，绝不是全部！因此，我们致力于管理体系变革与服务模式革新，重视项目的每一个环节与细节。从产品设计、研发、生产、销售、安装调试到服务的整个过程中，新值人都充满了创新性，并不断追求更富有挑战和创造性的工作。



测试中心 Test Center



实验物料 Materials for Experiments

NVM has the most professional technical testing laboratory with comprehensive equipment. The laboratory's existing bulk material database carefully confirms the performance parameters based on more than 2000 bulk material samples. Such as: air consumption, conveying pressure, speed and maximum capacity, material-to-air ratio, etc.

The laboratory can conduct a comprehensive test on the customer's specific bulk materials to obtain the actual conveying performance of the specific bulk materials and determine the best system operating parameters. mainly includes:

- Obtain verified important system design information. Such as material transportability, fluidity performance, etc.
- Obtain the optimized time and program logic of system equipment debugging and running.
- Obtain the actual quality of the material after the conveying operation. Such as degradation of materials, segregation of mixed materials, etc.
- Get the actual operating performance of the system. Such as: air consumption, dust collection, etc.
- Other properties that customers care about. Such as: particle size distribution and fluidity of materials.

Furthermore, the innovation does not merely rest on the product level, because we know deeply that the product is only one part, but not all of customer requirements. Therefore, we have been devoted to the management system reform and service mode renovation and focus on every chain and detail of project. During the whole process from product research, development, design, production and distribution till the service, NVM people are full of innovation to continuously seek for more challengeable and creative work.

业务范围 Business Scope

提供散料（颗粒、粉末、破碎料）处理所需的所有气力输送系统解决方案和设备。共有稀相负压系统、稀相正压系统、密相正压系统和密相负压系统四大类型。并提供气力输送系统应用中涉及到的散料的拆包、存储、干燥、计量配比、搅拌、除尘等系统方案和设备单元。

Provide all pneumatic conveying system solutions and equipment units required for bulk material (particles, powder, crushed materials, etc.) processing. There are four types of pneumatic conveying system (dilute phase negative pressure system, dilute phase positive pressure system, dense phase positive pressure system and dense phase negative pressure system). It also provides system solutions and equipment units for de-bagging, storage, drying, dosing, mixing and de-dusting of bulk materials involved in the application of pneumatic conveying system.

应用行业 Application Industries and materials

- ▶ 塑料应用相关行业：各种塑料颗粒、粉末、破碎料。如：PET, PA, PE, PP等；
 - ▶ 石油化工：PTA、催化剂等；
 - ▶ 橡胶轮胎：炭黑、硅粉等；
 - ▶ 玻璃玻纤：石英砂、白云石、芒硝等玻璃配合料；
 - ▶ 食品：面粉、糖、食盐、咖啡豆、奶粉等；
 - ▶ 医药：药片、胶囊等；
 - ▶ 宠物食品；
 - ▶ 动物饲料：玉米、维生素、氨基酸等；
 - ▶ 建筑业：建筑材料、涂料等；
 - ▶ 陶瓷；
 - ▶ 铸造：铸型砂等；
 - ▶ 环保：纯碱、石灰石等；
 - ▶ 电力：火电厂飞灰等；
 - ▶ 采矿：膨润土、长石、硼砂、石英、重晶石等；
 - ▶ 锂电池：正极材料、负极材料等；
 - ▶ 重工：粉煤、水泥等；
 - ▶ 农业：化肥、农药等；
 - ▶ 日化：洗衣粉、清洁剂等。
- ▶ Plastics related industry: Plastic granules, powder, regrind material. Such as: PET chips, PA granules, PE, PP pellets, PVC powder, etc;
 - ▶ Petrochemical: PTA powder, catalyst, etc;
 - ▶ Rubber Tire: Carbon black, silicon powder, etc;
 - ▶ Fiber glass: Silica sand, dolomite powder, Sodium sulfate, etc;
 - ▶ Food: Flour, sugar, salt, coffee bean, milk powder, etc;
 - ▶ Pharmaceutical: Tablet, capsule, etc;
 - ▶ Pet food;
 - ▶ Animal food: Corn, vitamin, amino acid, etc;
 - ▶ Construction: Building materials, painting materials, etc;
 - ▶ Ceramic;
 - ▶ Casting: Casting sand, etc;
 - ▶ Environmental protection: Soda ash, limestone, etc
 - ▶ Electric power: Fly ash, etc;
 - ▶ Mining: Bentonite powder, feldspar, sodium borate, quartz powder, etc;
 - ▶ Lithium battery: Anode material, cathode material, etc;
 - ▶ Heavy industry: Coal fines, etc;
 - ▶ Agriculture: Fertilizer, pesticide, etc;
 - ▶ Daily Chemical: Laundry detergent, etc.

物料 Materials



设备单元 Equipment Unit

逐层式自动拆包机 Automatic Bag Opening Machine

新值机械的DBL系列，逐层式自动拆包机，采用气缸抓手抓取整垛托盘上位于最上层料袋的物料，沿着移动导轨，经过一组圆形切刀，把抓取的一层物料料袋的底部切开，抖动料袋，物料落入底部缓存料箱，抓手把切过的空袋投入破袋压缩机内，然后进行托盘上下一层物料的拆包。

特别适用于各种颗粒物料、粉料的25KG整垛托盘的自动化拆包。可以在高效自动化拆包的同时，最大限度地避免料袋外的污染物混入拆后的干净物料，在塑料、化工、食品、饲料等各行业均有广泛应用。

The air cylinder grab is used to grab the materials in the uppermost bag on the pallets, along the moving guide rail, cut the bottom of the grabbed layer of material bag through a set of circular cutters, shake the bag, the materials fall into the bottom buffer box, put the empty bag into the bag compressor, and then unpack the next layer on the pallet.

It is especially suitable for the automatic unpacking the bag of 25kg on the whole stack pallets of various granular and powder materials. It can efficiently and automatically unpack and avoid the pollutants to the greatest extent. It is widely used in plastics, chemical, food, feed and other industries.



逐层式自动拆包机 Automatic Bag Opening Machine



气缸抓手 Gripper



空托盘堆栈机 Empty Pallet Stacker

技术特点 Technical Characteristics

- ▶ 产量高，每小时拆包数量可达400-1200包；
- ▶ 料袋外的污染物，几乎不会混入拆后的干净物料内，物料无污染风险；
- ▶ 拆净率高，物料极少残余在割后的破袋内，拆净率最高可达99.99%；
- ▶ 节能高效，主机安装功率仅需8.5KW；
- ▶ 自动化程度高，仅需一名工人操作完成所有拆包工作；
- ▶ 料袋适应性强，PE塑料袋，纸塑袋，麻布袋，编织袋等均均适用。25KG袋/50KG袋/75KG袋等均测试可用，料袋摆放不整齐，料袋杂乱放置等，均可无障碍运行；
- ▶ 自动化配置选项包括：待拆托盘辊轮输送带，空托盘堆栈机，拆后破袋压缩机，脉冲除尘器，料袋底部清扫清洁辊等。
- ▶ Greater throughput, the number of unpacks can reach 400-1200 sacks/h;
- ▶ Less material pollution: Less pollutants mixed into the material;
- ▶ Increased efficiency of raw materials, more than 99.9% empty;
- ▶ Energy saving, the installation power of the main engine is only 8.5kw;
- ▶ High automatic extent, Only one worker needs to use a forklift to put the full pallets to the lift;
- ▶ Unlimited sacks, PE plastic bag, paper plastic bag, sacks, woven sacks, and etc..25kg, 50kg, 75kg package are applicable; The bags are not placed in order, and the bags are placed in disorder, all of these conditions can operate without obstacles;
- ▶ Automatic configuration options include: empty pallet removal conveyor, empty pallet stacker, empty bag compactor, pulse dust collector, cleaning roller at the bottom of material bag and etc.

技术参数 Technical Data

型号 Model	包袋重量 Bag Weight (KG)	数量 Qty p/h	吨 Amount p/h	机器尺寸 Machine Size L*W*H (mm)	机器重量 Machine Weight (KG)
DBL400	25/50/75	400	10	5650*2280*3880	3000
DBL600	25/50/75	600	15	5650*2280*3880	3000
DBL900	25/50/75	900	22.5	5650*2280*3880	3100
DBL1300	25/50/75	1300	32.5	5650*2280*3880	3200

逐袋式自动拆包机 Automatic Bag Opening Machine

新值机械的DBB系列，单袋逐袋拆包式自动拆包机，采用横切三面环切的切袋方式，物料不与料袋外袋接触，完全避免料袋外袋污染物混入拆后的干净物料中。可达食品级，卫生级应用。操作简便、运行可靠、故障率低、拆后破袋物料清空率可达99.7%以上，产量可达9-12吨/小时。可适用于大部分规格和材质料袋包装的物料使用。逐袋式自动拆包机占地空间小，使用方便灵活，适用于塑料、化工、食品、饲料等各行业，设备可占地空间有限，对拆后物料品质要求高等应用情况。

NVM's DBB series automatic bag opening machine, adopts the cross cutting and three side circular cutting, and the materials do not contact with the Outside of packing bag, so as to completely avoid the pollutants outside mixing into the clean materials after unpacking. It can reach food grade and hygienic application. The utility model has the advantages of simple operation, reliable operation, low failure rate, over 99.7% emptying rate, and the output can reach 9-12 tons/hour. It can be used for materials packaged in bags of most specifications and materials.

This automatic bag opening machine occupies a small space and is convenient and flexible to use. It is suitable for plastics, chemical industry, food, feed and other industries. And suitable for applications where the space is limited and has high requirements for the quality of disassembled materials.

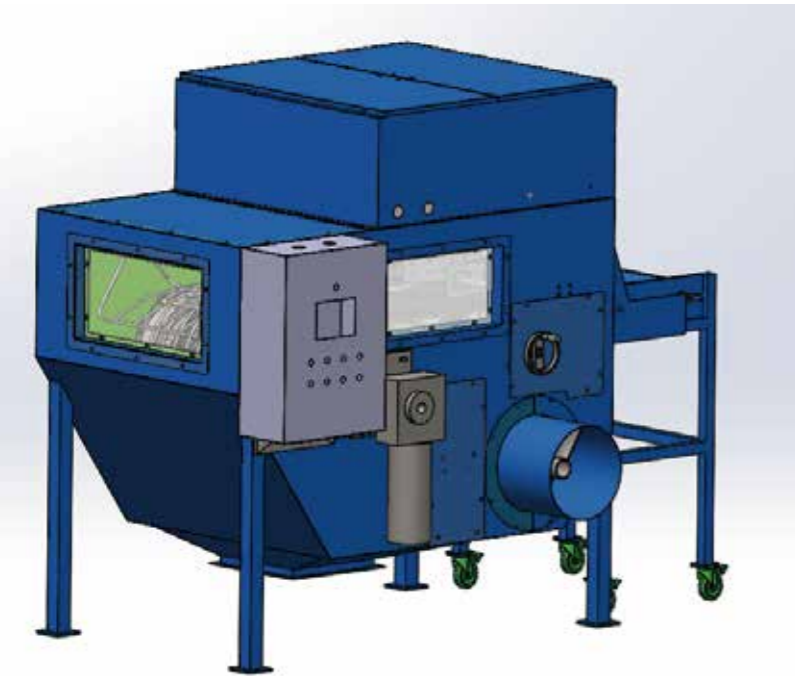

逐袋式自动拆包机 Automatic Bag Opening Machine



切割刀 Cutter Knife



捻袋挂钩 Hook

技术特点:

- 设备使用占地空间小。设备尺寸：长X宽X高：2380mmX1645mmX2025mm。
- 产能约每分钟6-8袋（根据物料不同变化）。
- 料袋外的污染物，几乎不会混入拆后的干净物料内，物料无污染风险。
- 拆净率高，物料极少残余在割后的破袋内，拆净率最高可达99.7%。
- 自动化程度高，仅需一名工人操作完成所有拆包工作。
- 料袋适应性强，PE塑料袋，纸塑袋，麻布袋，编织袋等均适用。
- 自动化配置选项包括：脉冲除尘器，CIP自动清洗系统，等。

Technical Characteristics

- This machine occupies a small space. Size: LxWxH: 2380mmx1645mmx2025mm.
- The capacity is about 6-8 bags per minute (depending on different materials).
- Less material pollution, Less pollutants mixed into the material;
- Increased efficiency of raw materials, more than 99.7% empty;
- High automatic extent, Only one worker needs to use a forklift to put the full pallets to the lift;
- Strong adaptability, PE bag, paper plastic bag, gunny bag, woven bag, etc. are applicable.
- Automatic configuration options include: pulse dust collector, CIP automatic cleaning system, etc..

技术参数 Technical Data

型号 Model	DBB360
产能 Capacity	6-8bags/min
安装功率 Installed Power	4.1kw
设备重量 Machine Weight	1250kg
设备尺寸 Machine Size (L×W×H)	2350mm×1120mm×2017mm
包袋重量 Bag weight	10/25/50kg

25KG手动拆包站 25KG Manual Unpacking Station

25KG手动拆包机是用于人工倾倒小袋装粉末或颗粒状物料至下游料斗内的手动设备，它通过人工拆袋自动倾倒等步骤使物料靠重力落入贮料斗中来完成拆袋卸料工作。该设备内部安装过滤器清洁装置及排风扇，用于过滤倾倒过程中产生的粉尘，并将洁净尾气排入大气，使工人能在清洁的环境中轻松地工作。

25kg manual unpacking station is a manual equipment used to manually dump small bags of powder or granular materials into the hopper. It makes the materials fall into the storage hopper by gravity through manual unpacking and automatic dumping. A filter cleaning device and an exhaust fan are installed inside the equipment to filter the dust generated during dumping and discharge, so that workers can work easily in a clean environment.

产品特点:

- 为用户考虑，本设备的整体尺寸紧凑，节省空间，结构精巧美观；
- 内置高效除尘器，维护方便，也可与中央集尘相连接；
- 可根据客户要求选择多种材质：不锈钢、碳钢等；
- 可配置自动切刀，并设置自动反馈，实现整体设备的连锁自动化；
- 整体结构、高度及料斗可根据用户的实际现场布置进行设计调整；
- 可配置压袋机进行废袋回收处理。

Product Features:

- For the consideration of users, the overall size of the equipment is compact, space saving.
- The built-in high-efficiency dust collector is convenient for maintenance and can also be connected with the central dust collector;
- Various materials can be selected according to customer requirements: stainless steel, carbon steel, etc;
- Automatic cutter can be configured and automatic feedback can be set to realize the interlocking automation of the whole equipment;
- The overall structure, height and hopper can be designed and adjusted according to the user's actual site layout;
- Bag pressing machine can be configured for waste bag recycling.



25KG手动拆包站 Manual Unpacking Station



立式安装筒式过滤器 Vertical Cartridge Filter



横式安装筒式过滤器 Horizontal Cartridge Filter

吨包拆包卸料站 Big-bag Discharge Station

吨包拆包卸料站主要应用于塑料、橡胶、食品、医药、化工等领域对大袋包装，如塑料树脂、食品添加剂等干燥粉、粒状物料进行拆包卸料。吨包拆包卸料机将吨袋包装物料提升到进料口，人工将包装袋下料口拆开后，打开流量控制阀和附带的振动下料装置促使包装袋内的粉粒状物料通过自重落入下方料斗中。

Big-bag discharge station is mainly used for large bag packaging in plastic, rubber, food, medicine, chemical industry and other fields, unpacking the dry powder and granular materials such as plastic and resin and food additives. The ton bag unpacking machine lifts the ton bag packaging materials to the feeding hopper. After manually opening the packing bag blanking port, open the flow control valve and the attached vibrating blanking device to make the powder and granular materials in the packing bag fall into the lower hopper through their own weight.

产品特点:

- 开袋站结构简单，便于操作；
- 用电葫芦或者叉车很容易将吨包输送至拆包工位上；
- 取料方便，物料在密闭的空间中流动，无粉尘泄露；
- 拍打装置帮助物料从吨包中流出，振动装置用于破除拱桥；
- 可以少量多次取用物料，也可作为存储料仓使用；
- 可以实现体积式计量和重量式计量；
- 自动控制系统实现连续拆包；
- 可以按照防爆要求制作。

注：特殊规格产品可以根据客户需求定制。

Product Features:

- The bag opening station is simple in structure and easy to operate;
- It is easy to transport ton bags to unpacking station by electric hoist or forklift;
- It is convenient to take materials, and the materials flow in closed space without dust leakage;
- Beat device helps materials flow out of ton bag, and vibration device is used to break the arch bridge;
- It can be used in a small amount of materials for many times, or as a storage bin;
- It can realize Volumetric and gravimetric dosing;
- Automatic control system realizes continuous unpacking;
- It can be made according to explosion-proof requirements.

Note: special specifications can be customized according to customer needs.



吨包拆包卸料站 Big-bag discharge station



双气缸拍打 Double Cylinder Beating

发送罐 Feed-tank

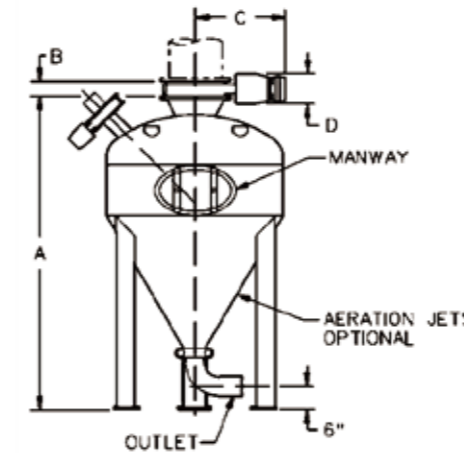
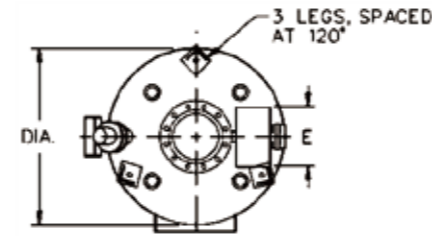

标准功能:

- 重型设计
- 内部光滑
- 60° 锥体
- 人孔
- 磨损表面的腐蚀裕量
- 气动蝶阀
- 可旋转出口

Standard features:

- Heavy-duty design
- Smooth interior
- 60° cone
- Manway
- Erosion allowances on wear surfaces
- Butterfly valve with pneumatic actuator
- Rotatable outlet

可选功能:

- 曝气射流
- 内涂层
- 多个入口
- 不锈钢结构
- 更高的压力和温度额定值

Optional features:

- Aeration jets
- Interior coatings
- Multiple inlets
- Stainless steel construction
- Higher pressure and temperature ratings

规格:

- 设计压力: 90 PSIG
- 温度范围: -29°C到+343°C

Specifications:

- Design pressure: 90 PSIG
- Temperature range: -29°C to + 343°C

发送罐 TRANSPORTER 60°					
型号 MODEL	容量CAPACITY (m ³)	A (m)	DIA (m)	重量 WEIGHT (kg)	
16-60-00.5	0.14	0.76	0.41	66	
16-60-001	0.03	0.86	0.41	73	
24-60-02.5	0.07	1.07	0.61	123	
24-60-005	0.14	1.37	0.61	134	
36-60-010	0.28	1.60	0.91	400	
36-60-015	0.42	1.83	0.91	454	
42-60-020	0.57	1.91	1.07	499	
42-60-030	0.85	2.29	1.07	567	
42-60-040	1.13	2.59	1.07	636	
54-60-060	1.70	2.74	1.37	896	
54-60-080	2.27	3.12	1.37	1032	
54-60-100	2.83	3.51	1.37	1168	
72-60-150	4.25	3.73	1.83	1565	
72-60-200	5.67	4.27	1.83	1906	
72-60-250	7.08	4.80	1.83	2257	
96-60-500	14.16	5.72	2.44	3969	
120-60-750	21.24	6.17	3.05	4536	
120-60-1000	28.32	7.16	3.05	5217	

进气阀 INLET VALVE					
尺寸 SIZE (mm)	B (mm)	C (mm)	D (mm)	E (mm)	重量 WEIGHT (kg)
150	54	521	127	305	23
200	64	521	153	277	28
250	64	540	153	277	35
300	77	604	204	401	69
400	102	677	204	508	137
450	108	718	204	508	152
500	153	753	204	508	193

Specifications subject to change without notice



输送系统现场图 Conveying System

空气控制单元 Air Control Unit

新值机械的ACU空气控制单元，应用在连续喂料型正压密相气力输送系统中，通过对压缩空气流量的调节控制，对通过高压旋转阀的物料，以恒定的空气流量、相对较低的线速度，进行密相气力输送。并能对通过高压旋转阀泄漏的压缩空气，进行自动流量补偿。

新值机械的ACU空气控制单元，基于国外最先进的控制技术，输送控制效率高（流量调节阀的压力降低于10%），输出线性好，可调节范围广，可以在设定的空气流量下，保持恒定稳定运行。

高压旋转阀正压密相气力输送系统，适用于对非磨蚀性物料，进行高产量、长距离地输送。因输送线速度低、料气比高，可避免物料与管道内部高速摩擦产生的拉丝、瞬时高温、管道设备磨损快、寿命短、混合物料输送产生分层偏析等弊端。保持输送后的物料高品质，无降解。

NVM's air control unit(ACU) is applied in the continuous feeding positive pressure dense phase pneumatic conveying system. The materials passing through the high-pressure rotary valve are transported by dense phase pneumatic conveying with constant air flow and relatively low linear speed by regulating and controlling the compressed air flow. And it can automatically compensate the compressed air leaked through the high-pressure rotary valve.

Based on the most advanced control technology abroad, the conveying control efficiency is high (the pressure of the flow regulating valve is reduced to 10%), the output linearity is good, the adjustable range is wide, and the constant and stable operation can be maintained under the set air flow.

High pressure rotary valve positive pressure dense phase pneumatic conveying system is suitable for high-yield and long-distance transportation of non abrasive materials. Due to the low speed and high material gas ratio, the disadvantages of wire drawing, instantaneous high temperature, pipe wear increasing, short service life, delamination and segregation can be avoided. Keep the transported materials of high quality without degradation.



旋转阀 High-pressure Rotary Valve



管道阀组 Valve Block

技术特点:

- 设定需要的空气流量方便简单。
- 针对不同的输送产线，适用不同的输送程序模块。
- 针对不同的产品性质，适用不同的输送参数。
- 根据输送压力，对高压旋转阀空气泄漏进行自动补偿。
- 根据不同的输送压力，输送产线，旋转阀尺寸，进行单独调节。
- 集成使用较高速压缩空气进行温柔清管的功能。
- 可对高达1:10的质量流量波动进行自动调节（根据输送距离）。
- 即使在低质量流量、大管径的系统中，同样可适用。
- 效率最高可达95%。
- 对噪音进行优化。
- 对高压和压力峰值的安全泄压进行自动控制。
- 可作为单独的控制单元，或者通过Profibus DP通讯及输入/输出模块，进行主系统集中控制。

Technical Characteristics:

- Easy set point setting for required air flow
- Programmable conveying modes for different conveying lines
- Programmable conveying parameters for different product characteristics
- Compensation of air leakage of rotary feeder depending on conveying pressure
- Individual adjustments depending on conveying pressure, conveying line, rotary feeder size
- Integrated process for gentle purging with higher air velocities
- Fluctuations of mass flow up to 1:10 automatically regulated (depending on conveying length)
- Even suited for low mass flow in large pipes
- Efficiency of 95 % in comparison to 85 % with sonic chokes
- Noise-optimised
- Automatic pressure control for safe relief of high pressure and pressure peaks
- Interface to main controls with Profibus DP, digital in-/output or as stand alone unit

技术参数 Technical Data

型号 Type	输送空气流量 Vg(Nm³/h)	空管空气流量 Vl(Nm³/h)	A	B	C
ACU32/16	350	500	1290	990	1590
ACU40/25	700	1000	1360	1100	2025
ACU50/35	1200	1700	1440	1100	2380
ACU65/60	1600	2300	1770	1900	3025
ACU80/80	2600	3800	1930	1900	3532
ACU100/100	3500	5000	2180	1900	4234
ACU100/160	4700	6700	2140	1900	4939
ACU125/200	5600	8100	2710	2100	5545

粉料负压吸料机 Powder Negative Pressure Receiver

新值机械的粉料负压吸料机，适用于粉料物料在负压稀相或负压密相的气力输送系统中，输送到达目的地之后的料气分离、物料卸料。

模块化的设计，可以方便更换不同的过滤器、下料方式、料位开关、进口管径等，以及零部件之间的完全互换性，可以灵活地适应客户现在或将来的各种使用要求。

NVM's powder negative pressure loader suitable for material gas separation and material unloading after powder materials are transported to the destination in the pneumatic conveying system of negative pressure dilute phase or negative pressure dense phase.

The modular design can facilitate the replacement of different filters, blanking methods, level switches, inlet pipe diameters, etc., as well as the complete interchangeability between parts, which can flexibly adapt to the current or future use requirements of customers.



负压吸料机 Negative Pressure Loader



除尘滤袋 Standard Receiver

Technical Characteristics:

- Carbon steel baking paint or stainless steel SUS304 structural material.
- No need tools for disassembly, assembly and maintenance.
- PTFE coated polyester filter is adopted.
- Filter pulse back blowing automatic cleaning function.
- High level switch.
- Vacuum block valve.
- Compressed air storage tank.
- It has different blanking methods such as rotary valve, butterfly valve and gate valve, which can carry out continuous or batch conveying of materials.
- Powered by separate vacuum unit equipment; When the output and distance meet the requirements, the fan can also be installed and integrated on the loader.

技术参数 Technical Data

型号 Model	标准容积 Standard Volume	设备尺寸 Equipment Size	压缩空气供应 Compressed Air Supply
PVR400	50L	直径(D)φ400mm; 高(H)1150mm	113-169L/min; 6-8bar; 干燥无油的干净压缩空气 Dry and oil-free clean compressed air
PVR500	100L	直径(D)φ500mm; 高(H)1790mm	113-169L/min; 6-8bar; 干燥无油的干净压缩空气 Dry and oil-free clean compressed air
PVR600	200L	直径(D)φ600mm; 高(H)1950mm	113-169L/min; 6-8bar; 干燥无油的干净压缩空气 Dry and oil-free clean compressed air

技术特点:

- 碳钢烤漆或不锈钢SUS304结构材质。
- 拆卸，组装，维护无需工具的设计。
- 采用PTFE涂层聚酯过滤器。
- 过滤器脉冲反吹自动清洁功能。
- 高料位开关。
- 真空截断阀。
- 压缩空气储罐。
- 具有旋转阀、蝶阀、插板阀等不同下料方式，可进行连续式输送或批次式输送物料。
- 由单独的真空单元设备提供动力；在输送产量和距离满足要求的情况下，也可把风机安装集成在吸料机上。
- 新值机械的研发测试中心，可提供免费试机服务，请与我司销售人员联系。
- The R&D and testing center of NVM can provide free test service, please contact our sales.

模块化负压吸料机 Modular Vacuum Receiver

新值机械的模块化负压吸料机，MVR系列，适用于散料物料在负压稀相或负压密相的气力输送系统中，输送到达目的地之后的料气分离、物料卸料。
模块化的设计，可以快速灵活地拆卸、安装，以及不同模块的互换性组合，极大地为客户降低成本、提高维护效率、增加吸料机的可使用寿命。

NVM's modular vacuum receiver, MVR series, suitable for material gas separation and material unloading after powder materials are transported to the destination in the pneumatic conveying system of negative pressure dilute phase or negative pressure dense phase.
The modular design can quickly and flexibly disassemble and install, as well as the interchangeable combination of different modules, which greatly reduces the cost, improves the maintenance efficiency and increases the service life.

技术特点:

- 不锈钢SUS304结构材质。
- 拆卸，组装，维护无需工具的设计。
- 多种过滤器类型可供选择，过滤器标配脉冲反吹自动清洁功能。
- 高料位开关。
- 真空截断阀。
- 具有旋转阀、蝶阀、插板阀等不同下料方式，可进行连续式输送或批次式输送物料。

Technical Characteristics:

- Carbon steel baking paint or stainless steel SUS304 structural material.
- No need tools for disassembly, assembly and maintenance.
- A variety of filter types are available, and the filter is equipped with pulse back blowing automatic cleaning function as standard.
- High level switch.
- Vacuum block valve.
- It has different blanking methods such as rotary valve, butterfly valve and gate valve, which can carry out continuous or batch conveying of materials.

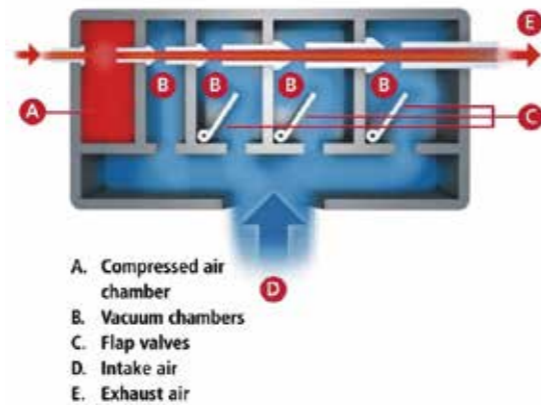

➤ 气体流向图 Air Flow

Modular interchangeable options:

- Different number of can body modules are combined with each other to form the required volume of the suction machine.
- Different types of level meters are suitable for different material types.
- Different types of filters adapt to different material types.
- Feed port components with different diameters can adapt to different conveying capacity.
- Different types of vacuum pump units are combined to adapt to dilute phase or dense phase conveying system.
- Vacuum pump units of different sizes are combined to adapt to different conveying capacity.
- Different types of blanking methods adapt to different system designs.



➤ 吸料机 Standard Receiver

模块化的可互换选择:

不同数量的桶体模块相互组合，可组成需要的吸料机容积。
不同类型的料位计，适应不同的物料类型。
不同类型的过滤器，适应不同的物料类型。
不同直径的进料口组件，适应不同的输送产能。
组合不同类型的真空泵单元，适应稀相或密相的输送系统。
组合不同大小的真空泵单元，适应不同的输送产能。
不同类型的下料方式，适应不同的系统设计。



➤ 模块部件 Module

真空泵 Vacuum Pump

真空泵，动力范围在1.5至11千瓦，产能高达1500kg/h，最大输送距离100m。
真空泵可以配备筒式过滤器或极其紧凑高效型的过滤系统以及过滤器，将气旋效应和尘埃分离完美结合，在落满灰尘的物料输送中尤其适用。

The vacuum pump, with a power ranging from 1.5 up to 11kW, cover a production range of up to 1500 kg/h and a transport distance of 100m maximum.

The vacuum pump can be equipped with cartridge filter or particularly compact and efficient filter system and filter, which perfectly combines cyclone effect and dust separation, and are recommended in the case dusty materials are conveyed.



➤ 基本式真空泵 Basic Vacuum Pump



带过滤真空泵 Vacuum Pump with filter ➤

优点:

- 免维护电机
- 噪音等级低于75dB(A)
- 过滤效率高
- 快速便捷的过滤清洗操作
- 垂直设计方案，占地面积小

Benefits:

- Maintenance-free motors
- Noise level lower than 75 dB(A)
- High filtering efficiency
- Quick and simplified filter cleaning operations
- Vertical design solution requiring little floor space



➤ 过滤器更换方便
Convenient Filter Replacement

手动配料站 Manual Coupling Station

新值机械手动配料站配备了基于卡口连接的创新型扭转连接器。这些连接器没有密封垫圈，垫圈可能接触塑料颗粒，造成可能的污染，并防止因真空损失而降低进料系统性能的任何风险。

有了新的连接器，不锈钢是唯一与塑料芯片接触的材料。连接操作简单快捷，只需一只手即可完成。该手动配料站配备了基于射频技术的标签系统，该系统包括一个本地LED，可立即显示连接的状态。

标签系统允许初步的一致性检查。如果进料系统控制检测到源头和目的地之间的连接不正确，则进料循环无法启动，从而避免任何错误或污染风险。该手动配料站标签系统还引入了标签识别功能。由于此附加功能，可以避免因物料线打开而错过进料周期。如果盖子缺失，则会产生特定的警报，操作员可以采取纠正措施，而不会危及进料系统的整体性能。

NVM's manual coupling station is the manual coupling station equipped with innovative twist couplers based on a bayonet connection. What makes these couplers different is the absence of a gasket that could get in contact with plastic granules with the consequence of possible contamination and prevents any risk of decreasing the feed system performance due to the loss of vacuum.

With the new couplers, stainless steel is the only material that is in contact with the plastic chips. The connecting operation is quick and easy and can be done with only one hand. This manual coupling station is equipped with a tagging system includes a local LED to immediately show the status of the connection.

The tagging system allows a preliminary consistency check. If the feeding system control detects an incorrect connection between source and destination, then the feeding cycle cannot start, avoiding any mistake or risk of contamination. This manual coupling station tagging system also introduces the function of cap recognition. Thanks to this additional feature it is possible to avoid missing feeding cycles due to open material lines. In the case of a missing cap a specific alarm is generated and the operator can take the corrective action without any risk of compromising the overall performance of the feeding system.

优点:

- 单手连接和操作
- 与材料接触时无任何密封
- 无因密封垫圈磨损而造成污染或真空损失的风险
- 通过射频技术指示正确的耦合，以避免错误
- 封口盖缺失，会产生特定的警报

Benefits:

- One hand connection and operation
- Absence of any sealing in contact with material
- No risk of contamination or of missing vacuum due to sealing wear
- Indication of the correct coupling thanks to RFID tagging system, to avoid mistakes
- Recognition of the presence of closing caps



玻璃管道配料站
Glass Pipe Coupling Station



快插接头
Quick Plug Connector



陶瓷管道配料站
Ceramic Pipe Coupling Station

自动配料站 Automatic Coupling Station

中央供料系统中的自动配料站拥有先进的清洁系统，集成在底部进口用来保证完美的主臂清洁效果和避免污染。制造新的主臂时通过特殊的硬化处理来保证最佳的耐磨性能。

最小化占地面积即使是带60进口/出口的最大型号。该自动配料站具有紧凑的垂直设计带不可进入的运动部件来保证操作人员的安全。当无污染对于应用很关键时，滑动门能够安装在每个出口作为屏障来避免残余颗粒。气动装配位置受编码器控制，确保正确选择原料来源。驱动器采用变频控制，速度快，移动精度高。

一套连接站能够控制最多60个原料来源和60个目的地，能够用所有或者其中一些进口和出口来配置，保证后续的扩展选项可用。连接站对于实现可靠完整的原料可追踪性必不可少。

This automatic coupling station range has a state-of-the-art cleaning system integrated in the bottom inlet to guarantee perfect cleaning of the main arms and prevent contamination. The new main arms are manufactured with a special hardening treatment for even greater wear resistance.

The floor space requirement is minimal even for the largest models with 60 inlets/outlets. This automatic coupling station has a compact, vertical design with moving parts inaccessible for optimal operator safety. In the case of applications where absence of contamination is critical, a slide gate can be installed on every outlet as a barrier against residual granules. Pneumatic fitting positions are encoder-controlled to ensure correct selection of the material source. The drives are equipped with inverters for fast, precise movements.

An coupling station is able to control up to 60 sources and 60 destinations, and can be configured using all or some of the inlets and outlets, keeping the option of subsequent expansions open. The coupling station is essential for reliable, complete material traceability.



自动配料站现场图 Automatic Coupling Station



立式结构
Vertical Structure

优点:

- 没有污染得益于领先的清管程序
- 高耐磨
- 维护简单
- 完全可追踪原料
- 最小占地面积和最大可进入性
- 杰出的多样性得益于宽广范围的直径选择和大量可能的进/出口组合

Benefits:

- No contamination thanks to state-of-the-art pipe cleaning procedure
- High wear resistance
- Simplified maintenance
- Completely traceable materials
- Minimal floor space occupation and maximum accessibility
- Outstanding versatility thanks to a broad range of diameters and the large number of possible inlet/outlet combinations

高压旋转阀 High pressure rotary valve

新值机械的高压旋转阀，工作稳定可靠，空气泄漏量低，工作压力可达3.5bar。适用在密相正压气力输送系统中，隔绝高压压缩空气，把物料定量添加到密相气力输送系统中。

高压旋转阀与空气管理单元一起，在设定的空气流量下，对物料进行密相正压输送。输送时：物料线速度低、料气比高、输送物料无破碎，输送后，物料可保持高品质，无降解。输送混合物料时，不偏析分层。并可减少输送管道等组件磨损，增加使用寿命。

The high-pressure rotary valve, stable and reliable operation, low air leakage, the working pressure can reach 3.5bar. It is suitable for dense phase positive pressure pneumatic conveying system to isolate high-pressure compressed air and quantitatively deliver materials to dense phase pneumatic conveying system.

Together with the air management unit, dense phase positive pressure conveying of materials under the set air flow. During transportation: the linear speed of materials is low, the material gas ratio is high, and no crushing. The materials can maintain high quality without degradation after transportation. When conveying mixed materials, there is no segregation and stratification. It can also

优点:

- 整体不锈钢SUS304结构材质。
- 设计压力3.5bar。
- 工作温度最高204℃。
- 腔体和转子密封设计，单点调节。
- 耐磨损进料口、出料口。
- 观察视镜。
- 填充率高。
- 清管空气零损失。
- 封闭式不锈钢转子。
- 密封转子轴承。
- 带腔体呼吸口。

Benefits:

- Overall stainless steel SUS304.
- Design pressure is 3.5bar.
- The maximum operating temperature is 204 °C.
- Cavity and rotor are seal, single point regulation.
- Wear resistant inlet and outlet.
- Sight glass.
- High filling rate.
- Zero loss of pigging air.
- Enclosed stainless steel rotor.
- Seal the rotor bearing.
- Breathing port with cavity.



➤ 高压旋转阀 High Pressure Rotary Valve



➤ 现场图 Installation Site

技术参数 Technical Data

型号 Mode Size	DIM B Inch	DIM C (mm)	DIM D (mm)	DIM E (mm)	DIM F (mm)	DIM H mm	DIM H1 (mm)	DIM J Inch (nominal)
HRV150-100	1.5 ~ 3	265	350	225	150	1,082	200	1.5
HRV200-150	1.5 ~ 5	315	415	270	180	1,172	200	1.5
HRV250-200	2.5 ~ 5	378	455	330	220	1,302	200	2
HRV320-250	3 ~ 6	486	565	390	260	1,452	200	2.5
HRV400-300	4 ~ 8	563	640	480	320	1,652	200	3
HRV480-350	5 ~ 8	613	685	530	350	1,852	200	3
HRV550-400	6 ~ 10	677	750	580	390	2,112	260	4
HRV630-500	8 ~ 14	804	850	680	460	2,522	300	4
HRV750-600	10 ~ 18	920	950	780	530	2,872	350	5
HRV800-700	12 ~ 20	1,035	1,015	880	600	3,192	400	6

失重式计量系统 Loss-in-weight Dosing System

新值机械的失重式计量系统是一款多组分持续失重式计量系统，具有自动重量/仪表调节功能，专为塑料材料（薄膜，管材，型材，单板和共挤板坯）的连续循环加工而设计。

这款精确的计量系统设计用于多达五个组件，允许各种配置。基于PLC的控制模块，用于全自动管理生产参数。

NVM's loss-in-weight dosing system is a continuous loss-in-weight multi-component dosing system equipped with an automatic weight/liner meter adjustment and designed for continuous cycle processing (film, pipes, profiles, mono and coextruded sheet).

This accurate dosing system is designed for use with up to five components for wide range of configurations. PLC based control module, it is used to automatically manage production parameters.



➤ 失重式计量站
Loss-in-weight Dosing Station

优点:

- 执行可靠
- 易于安装
- 完全预布线，即插即用
- 稀相和密相输送，输送压力高达2.0 barg
- 旋转管特殊涂层处理
- 快速分流移
- 轻便
- 内部易清洁

Benefits:

- Reliable execution
- Easy installation
- Completely pre-wired plug&play
- Dilute and dense phase conveying tight up to 2.0 barg
- Swivelling pipe hard coated
- Quick diversion
- Lightweight
- Inner easy accessibility

Loss-in-weight Dosing System
➤ 失重式计量系统现场图



称重式计量系统 Gravimetric Dosing System

新值机械的失重式计量系统配备了先进的触摸屏界面，可以轻松直观地管理机器和存储配方。称重斗在称重循环期间不受任何机械干扰，且不受振动影响。

每台机器可配置多种不同的料斗，以便为每种特定需求获得最合适的配置，并可轻松拆卸。该产品持续监控材料流量和每批产品以确保恒定的准确性。

该称重式计量系统可直接安装在加工机器的入口，地面的框架上或配备特殊的上料设备。该称重式计量系统提供以太网端口，配有 MODBUS 协议的RS485端口和可以轻松上传和下载数据的USB端口。

NVM's gravimetric dosing station is equipped with an evolved touch screen interface for an easy and intuitive management of the machine and for recipes storage.

The weighing hopper is free from any mechanical interference during the weighing cycle and immunity to vibrations. Each machine can employ nine different types of hoppers in order to obtain the most suitable configuration for any specific requirements and can be easily removable. The material flow rate and each batch are constantly monitored to ensure precision consistency.

This gravimetric dosing system can be installed direct on the machine throat, on a frame on the floor or equipped with a special suction tank. This gravimetric dosing system is provided with a ETHERNET port, RS485 port for the MODBUS protocol and with a USB port for easy upload and download of data.



称重式混料站
Gravimetric Dosing Station



称重式混料站细节图
Equipment Detail

特点:

- 准确度±0.1%
- 反应速度快
- 适用于微量计量

Features:

- 0.1% precision
- High reaction speed
- Suitable for microdosing

体积式混料机 Volumetric Doser

新值机械的体积式混料机，适用于对粒径、形状分布均匀的散料物料，包括颗粒、粉料、回收破碎料，进行计量配比，喂料。配比精度最高可达±0.3%。

该设备已经在挤出、吹膜、注塑等塑料成型相关行业广泛应用，运行稳定可靠。

NVM's volumetric doser is suitable for bulk materials with uniform particle size and shape distribution, including particles, powder and recycled crushed materials, the proportioning accuracy is up to ±0.3%.

It has been widely used in extrusion, film blowing, injection molding and other plastic molding related industries, stable and reliable.



体积式混料机
Volumetric Doser

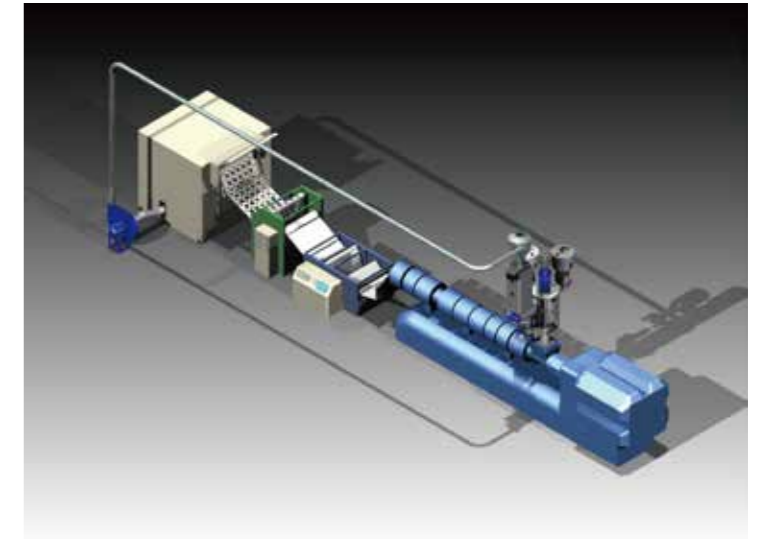

体积式混料系统
Volumetric Dosing System

特点:

- 不锈钢SUS304结构材质。
- 拆卸，组装，维护方便。
- 模块化选型组合。
- 快速进行物料更换。
- 配比精度高，混合均匀。
- 连续式挤出机喂料模式，或批次式注塑机喂料工作模式。
- 西门子PLC控制系统。触摸屏中、英文界面。

Features:

- Stainless steel SUS304.
- Easy disassembly, assembly and maintenance.
- Modular selection and combination.
- Quickly material replacement.
- High accuracy and homogeneous.
- Continuous extruder feeding, or batch injection molding feeding.
- Siemens PLC. Touch screen Chinese and English interface.

技术参数 Technical Data

型号 Model	最大流量 Maximum Flow (kg/h)	数量 N°max Dosers (N°)	计量电机功率 Dosers Motor Power (kw)	混合电机功率 Mixer motor Power (kw)	搅拌器叶轮类型 Agitator Paddle type	搅拌器叶轮速度 Agitator Paddle speed (rpm)	标准容积 Mixer Capacity (dm³)	设备尺寸 Dimension (mm)
VD25	200	4	0.18/0.25	0.37	Vertical	18	25	446×398×630
VD50	400	4	0.18/0.25	0.75	Vertical	18	50	547×477×823
VD75	600	4	0.18/0.25/0.37	0.75	Vertical	18	75	627×477×982
VD100	800	4	0.18/0.25/0.55	0.75	Vertical	18	100	577×477×1126

掺混料仓 Blending Silo

该工艺的原理是通过混合筒仓内的垂直混合管，同时从18个不同高度收集散装材料，并将其输送至中央混合室。在混合室中，18个分流与来自中央出口锥体的质量流混合并排出。为了达到这一目的，总共在内部安装了6个混合管，每个混合管有3个腔室，搅拌机出口的产品由整个筒仓的混合物组成。

The process is based on the principle of simultaneously collecting bulk material from 18 different heights, via vertical blending pipes within the blending silo, and routing it to a central blending chamber. In this blending chamber, the 18 partial flows are blended with the mass flow from the central outlet cone and discharged. A total of 6 blending pipes, each with 3 chambers, are installed internally to achieve this, and the product output at the blender discharge is made up of a mixture from the entire silo.



掺混料仓 Blending Silo

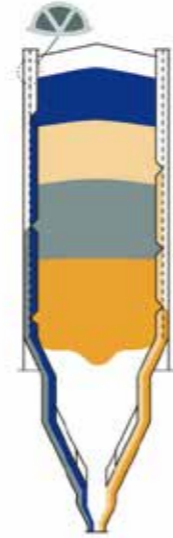

掺混料仓原理图
Blending Silo Schematic

特点:

- 批次均匀化
- 可在不同料位进行混合填充，最低料位约为25%
- 混合筒仓的设计优化了物料的质量流量，保证了良好的、可重复的均化结果
- 易于混合
- 对于许多连续性生产的应用，进行单次混料就足够了
- 无残留物料
- 可与排气结合使用
- 混合管焊接在筒仓壳体上
- 混合管不需要额外的固定件

Features:

- Batch homogenization;
- Can be used at different fill levels down to approximately 25%;
- The design of the blending silo, to optimize mass flow, guarantees a good, reproducible homogenization result;
- Easy integration into processing, a single cycle is sufficient for many applications in continuous operation;
- Residue-free emptying
- Can be used in combination with degassing;
- Blending pipes are welded to the silo shell;
- No additional fixings are required for the blending pipe.



普通储料仓 Storage Silo

这种料仓类型适用于混凝土基础的架设，主要用于加工行业。

This silo type is suitable for erection on a concrete foundation and is used mainly in the processing industry.



普通储料仓 Storage Silo

特点:

- 不锈钢材质
- 整体焊接
- 无需额外底座的经济选择
- 持久清洁，外观保持良好

Features:

- Stainless steel
- Overall welding structure
- Economical option without additional substructure
- Long-lasting clean and well-maintained appearance



储料仓底部 Storage Silo Bottom



储料仓顶部脉冲除尘器 Top Pulse Dust Collector

气力输送系统 Pneumatic Conveying System

正压密相发送罐气力输送系统

Positive Pressure Dense Phase Pneumatic Conveying System

使用相对较高的压力(1bar以上)，以相对较少的空气消耗，通过输送管道对粉末状或颗粒状的固体散料物料进行输送。

Use relatively high pressure (above 1bar), powdered or granular solid bulk material is transported through the conveying pipeline with relatively little air consumption.

- 打开发送罐的加料阀和呼吸阀，开始加料。
- 加料至发送罐的高料位位置，加料阀和呼吸阀关闭，加料结束。
- 输送压缩空气阀门打开，发送罐充气加压，管道助推器打开。
- 输送计时开始，物料从发送罐经由输送管道开始输送。
- 发送罐内物料输送完毕，压缩空气进气阀关闭。
- 系统进入下一批次的物料输送循环。

- Open the feeding valve and breathing valve of the delivery tank and start feeding.
- Feeding to the high material level position of the sending tank, feeding valve and breathing valve are closed, feeding is finished.
- The conveying compressed air valve is opened, the sending tank is inflated and pressurized, and the pipeline booster is opened.
- The conveying time starts, and the material starts to be conveyed from the sending tank through the conveying pipe.
- The material in the sending tank is conveyed, and the compressed air inlet valve is closed.
- The system enters the next batch of material delivery.



优点优势:

- 对颗粒、粉末和混合的物料等均适合;
- 高的输送产量;
- 低的物料磨损;
- 先进的管道空气助推器技术，独特的创新型气力输送方案，使输送更加高效、稳定、节能;
- 输送温柔，速度慢，磨损小;
- 混合物料无分层，品质无下降;
- 使用较低的压缩空气和能量消耗;
- 系统简单，无污染;
- 不锈钢材质，可适合于卫生级和防腐蚀应用。

Advantages:

- It is suitable for particles, powders and mixed materials;
- High transportation output;
- Low material wear;
- Advanced pipeline air booster technology and unique innovative pneumatic conveying project make the conveying more efficient, stable and energy-saving;
- Gentle conveying, slow speed and small wear;
- The mixture has no stratification and the quality has no decline;
- Use of low compressed air and energy consumption;
- The system is simple and pollution-free;
- Stainless steel, suitable for sanitary and corrosion resistant applications.

特征特点:

- 几乎可满足于大部分的输送产量和输送温度的生产要求。适合于:
- 高磨蚀性的物料;
- 易碎的物料;
- 混合的物料(使输送后的混合物料，几乎无分层或分层现象降至最低);
- 比重较重的物料;
- 具有吸湿性的物料。

Features:

- It can almost meet the production requirements of most of the conveying output and conveying temperature. Suitable for:
- High abrasion material;
- Fragile materials;
- Mixed materials (the mixed material after conveying, almost no stratification or keep stratification to a minimum);
- Materials with heavy proportion;
- Moisture absorbing material.



行业和物料:

- 塑料相关行业：塑料原料颗粒、粉末。如：PET, PE, PP等;
- 炭黑;
- 食品：谷类或易碎的谷粒、咖啡、花生、面团、糖;
- 化工;
- 日化：洗衣粉;
- 电厂飞灰;
- 宠物食品;
- 沙子等。

Industry and materials:

- Plastic related industries: plastic raw material particles, powder. Such as: PET, PE, PP, etc.;
- Carbon black;
- Food: cereals or fragile grains, coffee, peanuts, dough, sugar;
- Chemical industry;
- Daily chemical products; Washing powder;
- Fly ash from power plant;
- Pet food;
- Sand, etc..

正压密相高压锁气阀气力输送系统

Positive Pressure Dense Phase High Pressure Lock Valve Pneumatic Conveying System

正压密相高压锁气阀气力输送系统，同样使用相对较高的压力（1bar以上），以相对较少的空气消耗量，较低的输送速度，进行物料输送。

输送物料，经由特殊的高压锁气阀，喂入输送系统管道中。空压机的压缩空气，连接到我们创新研发的输送空气管理系统，输出稳定、精准的流量和压力，使喂入输送管道内的物料，保持最优化的料、气比，平稳地输送至目的地。

通常应用于对非磨蚀性的物料，进行连续性地输送。适合于顶部可使用的安装空间受限制，或者对物料降解较为敏感的情况。

Positive pressure dense phase high pressure lock valve pneumatic conveying system also uses relatively high pressure (more than 1bar), with relatively less air consumption, low transmission speed.

Materials, through the special high pressure lock valve, feeding into the conveying system pipeline. The compressed air of the air compressor is connected to our innovative delivery air management system, and the output is stable and accurate flow rate and pressure, maintain the optimization of the ratio of material to air of the material fed into the conveying pipeline, smoothly transported to the destination.

It is usually used for non abrasive materials, continuous transmission. Suitable for the limited space available at the top, or more sensitive to material degradation.



优点优势:

- 高的输送产量;
- 输送速度慢，管道磨损小;
- 料、气比高;
- 输送平稳，节能;
- 顶部安装空间相对要求不高。

特征特点:

- 适合于非磨蚀性的，易碎的，易降解的物料;
- 对高压锁气阀要求高。

Features:

- It is suitable for conveying non abrasive, fragile and degradable material;
- High requirements for high pressure air lock valve.

Advantages:

- High transportation output;
- The transportation speed is slow, and the pipeline wear is small;
- The ratio of material to gas is high;
- Stable transportation and energy saving;
- The top installation space is relatively low.

行业和物料:

- 塑料相关行业：塑料粉料，如：PTA等;
- 食品：谷类或易碎的谷粒、咖啡、花生、面团、糖、宠物食品。

Industry and materials:

- Plastic related industries: plastic powder, such as PTA, etc;
- Food: cereals or fragile grains, coffee, peanuts, dough, sugar, pet food.

正压稀相气力输送系统

Positive Pressure Dilute Phase Pneumatic Conveying System

正压稀相输送系统可以对散料，粉末和颗粒进行高产量，长输送距离地输送。

通常采用容积式风机（例如：罗茨风机、侧流风机等）提供动力，使用旋转阀或文丘里装置，把物料喂入到输送管道，利用压缩气流，把物料连续地输送到目的地。

物料在输送气流中处于悬浮状态。输送速率相对较高（具体速率取决于物料的颗粒粒径和密度等）。

The positive pressure dilute phase conveying system can deliver bulk material, powder and granules with high yield and long conveying distance.

Usually positive displacement fans (e.g. roots fans, side flow fans, etc.) are used to provide power, Use rotary valve or venturi device to feed the material into the conveying pipeline, the compressed airflow is used to continuously transport materials to their destination.

The material is suspended in the conveying air stream. The conveying rate is relatively high (The specific rate depends on the particle size and density of the material)



特征特点:

通常适合于以下性质的物料:

- 无磨蚀性的;
- 不易碎的;
- 密度小的（通常实密度在1 kg/dm³以下）。

优点优势:

- 输送产量大，距离远;
- 初始投资成本低;
- 系统的安装、操作、维护，都比较简单方便。

行业和物料:

- 塑料相关行业集中供料系统：塑料颗粒、粉料、破碎料、瓶片等
- 饲料行业集中供料系统

Features:

It is usually suitable for materials with the following properties:

- Non abrasive;
- Not fragile;
- Low density (usually with a real density of 1 kg/dm³ Below).

Advantages:

- The conveying capacity is large and the distance is long;
- The initial investment cost is low;
- The installation, operation and maintenance of the system are relatively simple and convenient.

Industry and materials:

- Plastic related industries centralized feeding system: plastic particles, powder, broken materials, bottles, etc;
- Centralized feeding system in feed industry.

负压稀相气力输送系统

Negative Pressure Dilute Phase Pneumatic Conveying System

负压稀相气力输送系统，通常由罗茨真空泵、或侧流风机等提供动力，利用负压吸料的方式，把物料从来源地，通过管道输送到目的地。通常安装有真空吸料机，用于输送到目的地后的料、气分离。

输送时，可通过手动配料站或自动配料站，对不同的物料种类，输送到不同的目的地，进行选择。负压稀相气力输送，适用于低、中等产量的物料的中等距离的从多个来源地到多个物料目的地的输送。

Negative pressure dilute phase pneumatic conveying system, the power is usually provided by roots vacuum pump or side flow fan, and the material is transported from the source to the destination through pipeline by means of negative pressure suction. A vacuum suction machine is usually installed to separate the material and gas after being transported to the destination.

When conveying, manual batching station or automatic batching station can be selected according to different material types or different destinations.

Negative pressure dilute phase pneumatic conveying system, it is suitable for medium distance conveying of low and medium output materials from multiple sources to multiple destinations.

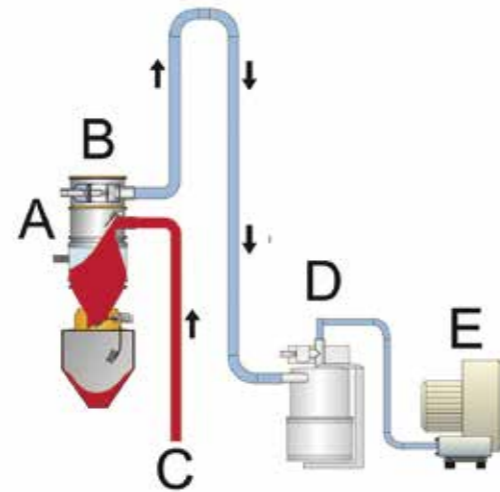

特征特点:

通常适合于以下性质的物料:

- 无磨蚀性的;
- 不易碎的;
- 密度小的 (通常实密度在1 kg/dm³ 以下)。

优点优势:

- 可做多物料来源地与多物料目的地，物料自由选择分配的，集中供料系统;
- 安装、操作、维护，简单方便。

行业和物料:

- 塑料相关行业集中供料系统: 塑料颗粒、粉料、破碎料、瓶片等
- 饲料行业集中供料系统

Features:

It is usually suitable for materials with the following properties:

- Non abrasive;
- Not fragile;
- Low density (usually with a real density of 1 kg/dm³ Below).

Advantages:

- It can be used as a centralized material feeding system with multiple material sources and destinations, free selection and distribution of materials;
- Installation, operation and maintenance are simple and convenient.

Industry and materials:

- Plastic related industries centralized feeding system: plastic particles, powder, broken materials, bottles, etc;
- Centralized feeding system in feed industry.

负压密相气力输送系统

Negative Pressure Dense Phase Pneumatic Conveying System

负压密相输送系统，使用高真空度的泵 (通常达到0.5bar) 作为动力，以较低的输送速度，从喂料料斗或大型储料仓，输送物料到达接收容器 (真空吸料机)。

负压密相输送适合于高产量的物料的短、中等距离的从多个来源地到一个或多个目的地的输送。低的输送速度和负压的方式，使得该系统适合于食品、乳制品、制药等行业里，易碎的或团聚的粉末等物料的输送。

负压密相输送系统，通常应用于相对较短的输送距离内的，连续式输送。如：卡车，轨道列车的卸料。

Negative pressure dense phase conveying system, use a high vacuum pump (usually 0.5bar) as power, the material is transported from the feed hopper or large storage bin to the receiving container (vacuum suction machine) at a lower speed of delivery.

Negative pressure dense phase transportation is suitable for short or medium distance transportation of high-yield materials from multiple sources to one or more destinations. This system is suitable for food, dairy, pharmaceutical and other industries with low conveying speed and negative pressure.



特征特点:

- 防爆和安全。
- 特别适合于流动性困难的物料。
- 可用于有毒物料。
- 可用于核能，石化等特殊行业。
- 可根据输送的物料和工作环境采用适合的制造材料。如：碳钢，不锈钢，合金，氟橡胶，丁晴橡胶等。根据输送的物料对制造的材料做不同的表面处理：电解抛光，镜面抛光，硫化，铁氟龙涂层等。

Features:

- Explosion proof and safety.
- Especially suitable for materials with difficult flow.
- It can be used for toxic materials.
- It can be used in nuclear power, petrochemical and other special industries.
- Suitable manufacturing materials can be used according to the conveying materials and working environment. Such as: carbon steel, stainless steel, alloy, fluororubber, NBR, etc. Make different surface treatment according to the different conveying materials: electropolishing, mirror poishing, vulcanization, teflon coating, etc.

优点优势:

- 对易碎散料的温柔输送;
- 输送时不会破坏敏感散料物料的结构;
- 输送热敏感散料时不破坏;
- 输送物料无降解;
- 现场就地清洗真空吸料机。
可达卫生级应用标准。

Advantages:

- Gentle conveying of fragile bulk materials;
- The structure of sensitive bulk materials will not be damaged during conveying;
- No damage during conveying heat sensitive bulk materials;
- No degradation;
- Clean the vacuum suction machine on site.
It can reach the hygienic application standard.

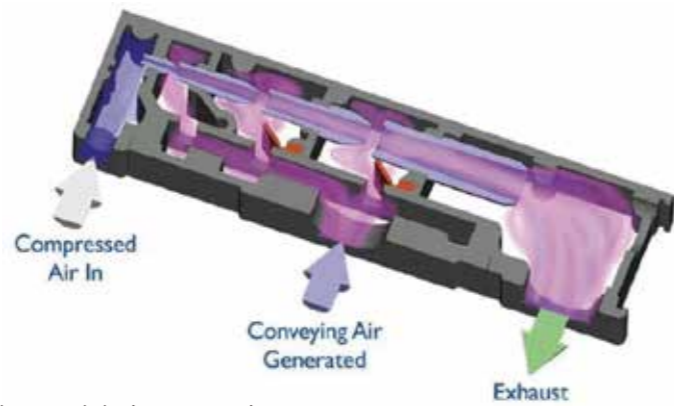

行业和物料:

- 塑料相关行业: 塑料原料颗粒
- 食品: 面团、糖果、坚果、巧克力豆等
- 医药: 药片、胶囊等
- 石化
- 核能

Industry and materials:

- Plastic related industries: plastic raw material particles;
- Food: dough, candy, nuts, chocolate beans, etc;
- Medicine: tablets, capsules, etc;
- petrifaction;
- nuclear energy.



行业应用 Industry Applications

PVC配混料自动化生产线 PVC Mixing and Batching System

PVC型材(管材)配混料全自动化生产线是我们经过多年生产实践完善, 专业为PVC型材和管材设计的自动化生产线。

Fully automatic production line for PVC profile (pipe) mixing material is an automatic production line specially designed for PVC profile and pipe after years of production practice.

自动化生产线以配料单元和混料单元为中心, 结合储存、输送、自动化控制等单元, 整个生产过程实现自动化, 生产过程和生产数据报表由上位机直接控制和输出。整个生产线可实现全程联动控制也可以实现各个单元独立控制, 极大的方便了生产操作和生产线的维护。配料单元我们使用世界上先进的仪器设备和我们专业为配料单元设计制造的计量配料螺旋, 保证了配料的精确和配料的速度。混料单元我们可以为你提供世界上最先进的混合机保证整个生产线的产量和质量。

The automatic production line centers on the batching unit and the mixing unit, and combines the storage, transportation, automatic control and other units to realize the automation of the whole production process. The production process and the production data report are directly controlled and output by the upper computer. The whole production line can realize the linkage control of the whole process and the independent control of each unit, which greatly facilitates the production operation and the maintenance of the production line. Batching unit we use the world's advanced instruments and equipment and our professional design and manufacture for the batching unit of the metering batching screw, to ensure the accuracy of the batching and batching speed. Mixing unit we can provide you with the world's most advanced mixer to ensure the production and quality of the entire production line.



项目: PVC配混料系统用于塑料挤压生产线 Project: PVC mixing and batching system for plastic extrusion

我公司可以提供PVC型材和管材生产线的总承包业务, 包括整厂设计、全部设备的调试以及交钥匙工程。

我们可以为客户提供:

- 全套的设计技术文件;
- 提供全部设备的技术文件, 包括挤出机、模具、公用工程(水、气、电);
- 提供整厂总承包工程的设备调试和过程检验;
- 为客户提供技术和员工的培训;
- 根据客户需要可以派出技术人员在对方工厂进行1-2年的工作, 以保证该项目能够成功实施。

our company can provide the general contracting business of PVC profile and pipe production line, including the whole plant design, commissioning of all equipment and turnkey project.

We can provide customers with:

- A full set of design technical documents;
- Provide technical documentation for all equipment, including extruders, molds, utilities (water, gas, electricity);
- Provide equipment debugging and process inspection for the whole plant's general contract project;
- Provide technical and staff training for customers;
- According to the needs of customers, technicians can be sent to work in the other party's factory for 1-2 years to ensure the successful implementation of the project.

食品级方案 Food Industry

新值机械有一整套食品原料处理的解决方案，从系统设计、设备选材、制造、安装、控制等全方位多角度考虑生产的洁净、便利与安全。针对部分食品设备采用先进的CIP定位清洁系统，采用不同的输送方式，有效保证物料的品质安全。从解包投料、储存破拱、研磨筛分、金属检测、异味去除、温湿控制、气力输送、计量配料到混合搅拌的整个过程中最大限度的做到不允许残留而导致细菌的滋生，无法避免的地方应确保便于清洁。

针对部分食品设备采用先进的CIP定位清洁系统，在管道的处理上新值机械采用风源净化处理技术和双管道清管技术，原料处理过程中根据其特点进行除铁、筛分、粉碎等工艺操作，灵活采用不同的输送方式，有效保证物料的品质安全。

NVM has a full set of solutions for food material handling. From system design, equipment material selection, production, installation and control and other aspects, we think of cleanliness, convenience, and safety with comprehensive consideration and multi-angle analysis. We use advanced CIP cleaning system for a part of food production, flexibly select different conveying methods as per materia respective properties to efficiently make sure the quality safety of the material.

From unpack discharging, arch breaking storage, grinding and screening, metal detection, smell removing, temperature and humidity controlling, pneumatic conveying, dosing and blending, for the whole production process, we minimize the residual to avoid bacteria breeding, the area where residual problem can't be avoided, we will ensure cleaning convenience.

We use advanced CIP cleaning system for a part of food production, choose wind source cleaning technology and twin pipe cleaning technology for pipeline treatment. Regarding deironing, screening, smashing and other process steps for raw material treatment, we flexibly select different conveying methods as per materia respective properties to efficiently make sure the quality safety of the material.



项目：白糖密相输送系统

Project: White Sugar Dense Phase System

➤ 服务：指定、供应并调试浓相输送系统，将6吨/小时的糖输送至270m的距离。

➤ Service: Specify, supply and commission a dense phase conveying system to transport 6TPH of Sugar a distance of 270m.

自动化趋势 Automation Trend

近年来人民生活水平不断的提高，大众对食品行业的要求也越来越严格。这给食品生产商带来更多挑战，“小、散、低”是目前的普遍现象。食品厂商要想立于不败之地，食品生产必须要实现机械化、自动化、专业化和规模化，要从传统的手工劳动和作坊式操作中解脱出来，提高卫生安全性和生产效率。

Along with constantly improvement of people's living standard in recent years, people's requirements on food become more and more strict, which brings many challenges to food manufacturers. Small scale, low capacity and product variety are universal problems faced by most of the food manufacturers now. A food manufacturers who wants to be invincible in the market shall achieve production mechanization, automation, professionalization and large scale, get rid of manual work and small workshop operation, improve sanitary safety and production efficiency.

近年来人们对塑料和橡胶的需求越来越大，家用电器中塑料原材料所占比例分别为：吸尘器60%，电冰箱38%，洗衣机34%，电视机23%，空调10%；汽车材料塑料化可减轻汽车自身重量，汽车自身重量每减少10%，燃料的消耗可降低6%~8%；在电线电缆领域，其绝缘外套的主要材料都是改性塑料。可以看出塑料市场的前景广阔，越来越多的企业进入塑料行业，随着人力成本的增加，想要在塑料行业生存，必须得改变原有的人工生产线，用全自动的现代化生产线提高车间环境和产品质量。

People's demand on plastic and rubber is increasing in recent years, percent-age of plastic used on each household appliances is as follows: dust collector 60%, refrigerator 38%, washing machine 34%, TV 23%, air conditioner 10%; plasticization of car material can reduce the weight of the car, with every 10% reduction of car weight, fuel consumption can be reduced by 6%~8%; in cable and electric wire fields, major material of the insulation cover is made of modified plastic. From above we can see that plastic market is promising, more and more enterprises entered into plastic industry, but with the increasing of the labor cost, an enterprise who wants to survive in the plastic industry, must change the existing manual production line, using full automated and modernized production line to improve the environment of the plant and quality of the product.

新值机械已与国内多家知名橡塑企业进行生产线的规划与改造，从客户项目立项开始参与，提供从物料解包投料、仓储、输送、自动混配，主机以及后端设备至包装的整线规划方案，提供厂房布局、水电气路设计，钢架平台、除尘系统、废气处理系统等。优化现场局部方案，以安全、高效、环保的理念结合专业的技能为客户提供配套服务。

NVM has successful experiences of production line planning and reconstructing for many famous rubber and plastic enterprises, When customer's project established, we provide entire line planning from unpack discharging, storage, conveying, automatic mix batching, host and back end equipment and finally to packaging, as well as provide plant lay out design, designs of water, electricity and gas lines, steel frame platform, dust removal system, exhaust treatment and other industrial process stages planing. Optimizing on site layout plan, combining professional skills with safe, efficient and environmental friendly concepts to provide supporting service to customer.



橡塑行业用到的主料原料有PA6、PA66、PA46、PA12、POM、PBT、PMMA、TPU、TPX、TPV、TPE、TPEE、PC、PC/ABS、PPA、PPS、PEI、PES、PSU、PPSU、EVA、CPE、PE、PA、PEEK、PP、PS、PPO、PBT等。

辅料及添加剂有炭黑、白炭黑、黑炭黑、钛白粉、碳酸钙、高岭土、膨润土、滑石粉、淀粉、开槽灰、稳定剂、土黄（色砂）、阻燃剂、增塑剂、着色剂、木粉、玻璃纤维、环氧树脂等。

液体原料有TOTM、DOP、DINP、DHP、DOA、环氧大豆油、白油、DMC、ESO、石蜡、对苯、粗对苯、内润滑剂、外润滑剂等。

The main raw materials used in rubber and plastic industry include PA6,PA66,PA46,PA12,POM,PBT,PMMA,TPU,TPX,TPV,TPE,TPEE,PC,PC/ABS,PPA,PPS,PEI,PES,PSU,PPSU,EVA,CPE,PE,PA,PEEK,PP,PS,PPO,PBT,etc..

Auxiliary materials and additives include carbon black, white carbon black, black carbon black, titanium dioxide, calcium carbonate, kaolin, bentonite, talc powder, starch, slotted ash, stabilizer, earth yellow (colored sand), flame retardant, plasticizer, colorant, wood powder, glass fiber, epoxy resin, etc..

Liquid raw materials include totm, DOP, DINP, DHP, DOA, epoxy soybean oil, white oil, DMC, ESO, paraffin, p-benzene, crude p-benzene, internal lubricant, external lubricant,etc..

物料输送在化工行业中比较复杂，由于化工行业经常面对不同特性的物料，化工物料的输送应充分考虑其温控环境、干湿度要求下料、洁净度等各种性能参数和物化要求。新值机械有专业的粉、粒、块料性能实验分析能力和输送管道分流的样本分析大数据储备基础，针对具体项目做出较为精准的输送参数和管道优化设计能力。设计中根据现场的物料运输，使用方便和场地条件做出合理的布局和承重设计。

Material conveying in the chemical industry is relatively complicated due to various of materials that with different properties. For chemical conveying, we must take full consideration of the temperature controlling, dryness and humidity requirements, discharging cleanliness and other performance parameters and physicochemical requirements. NVM has professional experimental analysis ability for powder, granule and lump material, and has a large data reserve base for pipeline diversion. Making precise conveying parameters and optimizing pipeline design according to detailed project. Making reasonable layout and load-bearing design according to the on-site material conveying, convenient use and site conditions.



化工行业最注重的是安全问题，事故发生会造成无可挽回的损失。新值机械拥有专业的防爆设计工程师，与国内外先进的防爆设备厂商合作，在系统设计上把握每一个安全环节，给客户专业的防爆设计考虑，每个项目都有专业的安全人员对工程进行验收，确保项目的风险降到最低。

Safety is the most important point in chemical industry, irremediable loss will occur if any accident happens. NVM has professional explosion proof engineers, cooperating with advanced explosion proof equipment manufacturers at home and abroad, grasping every safety details on the system design, providing the most professional explosion proof design to our customers. Every project will be inspected by professional safety engineer to minimize the safety risk of the project.

塑料改性 (Compounding)，是指通过对基础树脂进行一系列填充、共混等手段来改善物料性能，扩展应用范围。挤出机共混改性涉及原料有粉料、粒料形式的基础树脂，滑石粉、碳酸钙，玻纤，色母粒和其它粉料添加剂等。原料根据其配方比例不同，以及原料物料特性不同，需要专业的原料处理方案解决挤出机连续、稳定和精准的喂料。成品输送根据产品特性设计相应的输送及掺混方式，解决物料磨蚀和交叉污染等一系列问题。

Compounding refers to filling and mixing of minerals or additives into basic resin and through extruding to improve properties so as to expand application field. Compounding involves raw materials including basic resin, talc, CaCO₃, fiber class, master batch and additives. The way of transferring all these raw materials into extruder should be carefully design based on material characteristics and recipe requirement. Finished product conveying design based on material properties, to avoid material abrasion and cross contamination.



技术优势 Technical Advantages

- 原材料预处理：干燥、脱气、混合及自动配料
 - 成品处理：掺混、脱气、除粉、自动清洗和包装
 - 避免交叉污染：管道、料仓和包装机配置自动清洗和烘干系统
 - 磨蚀性物料：（如玻纤填充）输送密相输送及特殊弯头
- Pretreatment of raw material: Drying, degassing, mixing and automatic proportioning
 - Finished products handling: Blending, degassing, dedusting, packing and automatic silo washing
 - Avoid cross-contamination: Automatic washing and drying system for pipe, silo and packing machine
 - Conveying of abrasive material: Conveying of abrasive material (e.g. material stuffed with fiber glass) Dense phase conveying and use of special bend

方案价值 Scheme Value

- 提高效率，节省成本，专有的集装箱及吨袋自动卸料技术
 - 减少粒料破损率和残留 优化的气力输送系统
 - 满足生产对清洁和GMP的要求，快拆式设备设计和模块化单元设计
 - 不同主机和辅料配料精度的要求，全自动配料系统提供在线配方管理和历史数据查询和下载
- Improve efficiency and save costs Proprietary Automatic Unloading Technology for Containers and Bags
 - Reduction of breakage and residue of aggregates Optimized pneumatic conveying system
 - Meet the requirements of clean production and GMP. Design of Quick Disassembly Equipment and Modular Unit Requirement for the accuracy of different main ingredients and accessories
 - Fully automatic batching system Provides online recipe management and historical data query and download.

随着环保节能的理念深入人心，新能源项目也越来越备受关注，目前中国锂电池材料生产企业行业影响逐渐增大，全球占有率逐年上升，发展前景较好。但锂电池负极材料大多为粉体材料，石墨等负极材料粉碎后粉末较为细小，容易引起粉尘飞扬。过去的负极材料生产完全依赖人工，生产环境极其恶劣，而气力输送则让负极材料生产实现了自动化、无人化和无尘化。

With the concept of environmental protection and energy conservation deeply rooted in the people's hearts, new energy projects are also more and more concerned. At present, the influence of China's lithium battery material production enterprises has gradually increased, the global share has increased year by year, and the development prospects are good. However, most of the negative materials of lithium battery are powder materials, and the powder is smaller after the negative materials such as graphite are crushed, which is easy to cause dust flying. In the past, the negative material production was completely dependent on human, and the production environment was extremely bad, and the pneumatic transportation made the negative material production realize automation, unmanned and dust-free.



气力输送在锂电池材料生产中的优势:

- 气力输送管道密闭无泄漏，可实现密闭生产，提供无尘清洁的车间环境；
- 减少粉尘、物料泄漏，不仅环保无污染，还节省了原料，提高生产效率；
- 实现自动化生产，降低工人劳动强度，减少人员劳动成本；
- 可配套自动配料系统，计量精准，减少人为因素，可提高产品质量；

Advantages:

- The pneumatic conveying pipeline is airtight without leakage, which can realize airtight production and provide dust-free and clean workshop environment;
- Reduce dust, material leakage, environmental protection and pollution-free, but also save raw materials, improve production efficiency;
- Realize automatic production, reduce labor intensity and labor cost of workers;
- It can be equipped with automatic batching system, accurate measurement, reduce human factors, and improve product quality;



锂电池材料生产中气力输送的难点:

- 物料分层：锂电池正负极材料对材料的一致性要求较高，即要求有均匀的颗粒尺寸。但在气力输送过程，由于输送的特性，会产生分层现象，即大颗粒低速输送、小颗粒高速输送；
- 金属含量：锂电池负极材料质量评价的一个重要标准是材料中金属成分的含量。金属含量超标，不仅会使电池放电速度加快，还会影响电池的安全性能；
- 电气控制设备：锂电池负极材料具有导电性，因此对电气控制柜和电气设备会有比较高的要求，否则在生产过程中会有很大的风险。

Difficulties:

- Material layering: the positive and negative electrode materials of lithium batteries require high consistency of materials, that is uniform particle size. However, in the process of pneumatic conveying, due to the characteristics of conveying, there will be stratification phenomenon, that is low-speed conveying of large particles and high-speed conveying of small particles;
- Metal content: one of the important standards for the quality evaluation of lithium battery anode materials is the content of metal components in the materials. Excessive metal content will not only accelerate the discharge speed of the battery, but also affect the safety performance of the battery;
- Electrical control equipment: lithium battery anode material has conductivity, so there will be higher requirements for electrical control cabinet and electrical equipment, otherwise there will be great risk in the production process.

